

# TS4601

## High-performance stereo headphone driver with capa-less outputs and I<sup>2</sup>C bus interface



This high-performance headphone amplifier with peerless power supply rejection ratio (PSRR) values, adds to **STMicroelectronics'** (ST) substantial portfolio of audio amplifiers for portable applications.

Designed specifically for battery-operating devices such as mobile phones, the high PSRR value ensures that quality sound can be delivered even with a direct supply from the battery. Special attention to the input stage design provides for a very high signal-to-noise ratio.

This device can drive 16-ohm (min.) stereo headphones and can also drive an external line-out. This capability allows, for instance, customers to use their mobile phone to play music on a mini-hifi unit.

### Key features

- Power supply range: 2.9 V to 5.5 V
- Integrated LDO to achieve a PSRR of 100 dB at 217 Hz and up to 1 kHz
- Fully differential inputs
- SNR: 100 dB
- Output-coupling capacitors removed
- I<sup>2</sup>C interface for volume control
- Digital volume control range from -60 dB to +4 dB
- Independent right and left channel shutdown control
- Low quiescent current
- Low standby current
- Flip-chip package 2.1 mm x 2.1 mm, 500 µm pitch, 16 bumps

### Main applications

- Mobile phones
- Portable audio players
- Portable media players
- Notebooks

## TS4601 in a typical application

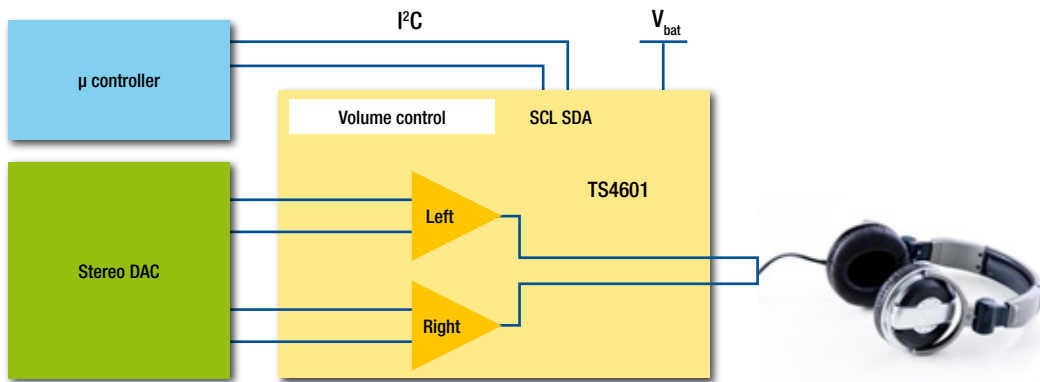

The TS4601 is a high fidelity stereo headphone amplifier that has been designed specifically to achieve excellent audio performance for applications where there are significant board space constraints. An incredible PSRR of almost 110 dB at 217 Hz (100 dB at 1 kHz) means that this compact 16-bump flip-chip device can be directly supplied by a battery.

Volume is controlled by an I<sup>2</sup>C bus interface, providing 64 steps from -60 dB up to +4 dB with a minimum step of 0.5 dB for the higher gain settings. Differential inputs offer better noise immunity, and special care has been given to the input stage design, resulting in a signal-to-noise ratio of 100 dB.

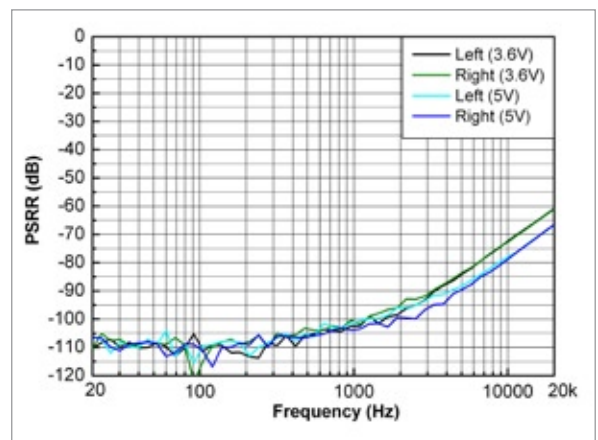

PSRR vs. frequency measurements for the TS4601

Outputs are single-ended and referenced to ground; meaning no output capacitors are needed for the headset connector. A common-mode sense has been integrated to the device that eliminates any voltage difference between the headphone jack return and the ground of the TS4601.

The TS4601 can drive a traditional headset having a 16 Ω load minimum. This device also has the ability to drive higher loads, such as for an external audio amplifier. In this scenario, the TS4601 can drive a 1.6 V<sub>rms</sub> audio signal into a 10 kΩ load, with very good stability on a wide range of capacitive loads (from 0.8 nF up to 100 nF).



© STMicroelectronics - November 2007 - Printed in Italy - All rights reserved

The STMicroelectronics corporate logo is a registered trademark of the STMicroelectronics group of companies. All other names are the property of their respective owners.

For selected STMicroelectronics sales offices fax:

China +86 21 34054689; France +33 1 55489569; Germany +49 89 4605454; Italy +39 02 8250449; Japan +81 3 57838216; Singapore +65 6481 7771; Sweden +46 8 58774411; Switzerland +41 22 9292900; United Kingdom and Eire +44 1628 890391; USA +1 781 861 2678

Full product information at [www.st.com](http://www.st.com)

Order code: FLHPAMP1107

